

PRODUCT FEATURES

"Racing" Oil Filters

- Heavy duty steel body construction to resist high pressure surges and external impact.
- Low-restriction racing media designed for high oil flow.
- Spiral-shaped centertube provides protection against collapse.
- Heavy gauge steel tapping plate withstands high pressure flexing.
- Screen-over by-pass valve provides additional protection against larger contaminants - ALL NEW!



"Racing" Air Filters

- Two grades of media for both asphalt and dirt track use.
- 16" and 14" diameter sizes.

"Racing" Fuel Filters and Fuel Cartridges



- HPG1 designed for fuel flows up to and including 90 GPH and can withstand 200 PSI of pressure.
- New HPG2 (large) and HPG3 (small) in-line fuel filters.
- Replacement cartridges for all.

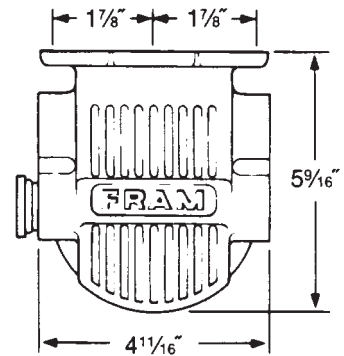

"Racing" Mounting Kits

- Provide more flexibility and applications for FRAM "Racing" oil filters.

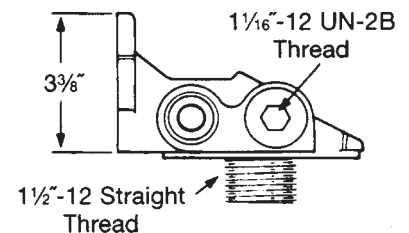

FRAM

SHIP • RELIABLE PARTS • DEPENDABLE SERVICE • QUALITY CRAFTSMANSHIP • RELIABLE PARTS • DEPENDABLE SERVICE

LEXINGTON MOORESVILLE
1(800)222-6805 • 1(800)615-6759
FAX: 1(336)249-4922 • www.centralhp.com

